

MENIIT

NEET | IIT-JEE | FOUNDATION

Corporate Office: 44-A/1, Kalu Sarai, New Delhi 110016 | Web: www.meniit.com

JEE MAINS-2019

12-01-2019 Online (Evening)

IMPORTANT INSTRUCTIONS

1. The test is of 3 hours duration.
2. This Test Paper consists of **90 questions**. The maximum marks are 360.
3. There are three parts in the question paper A, B, C consisting of **Mathematics, Chemistry and Physics** having 30 questions in each part of equal weightage. Each question is allotted 4 (four) marks for correct response.
4. Out of the four options given for each question, only one option is the correct answer.
5. For each incorrect response 1 mark i.e. $\frac{1}{4}$ (one-fourth) marks of the total marks allotted to the question will be deducted from the total score. No deduction from the total score, however, will be made if no response is indicated for an item in the Answer Box.
6. Candidates will be awarded marks as stated above in instruction No.3 for correct response of each question. One mark will be deducted for indicating incorrect response of each question. No deduction from the total score will be made if no response is indicated for an item in the answer box.
7. There is only one correct response for each question. Marked up more than one response in any question will be treated as wrong response and marked up for wrong response will be deducted accordingly as per instruction 6 above..

PART-A-MATHEMATICS

1. There are m men and two women participating in a chess tournament. Each participant plays two games with every other participant. If the number of games played by the men between themselves exceeds the number of games played between the men and the women by 84, then the value of m is

(1) 9 (2) 7 (2) 11 (4*) 12

Sol. $2 \cdot {}^m C_2 = 84 + 2 \cdot {}^m C_1 \cdot {}^2 C_1$

$$\Rightarrow m(m-1) = 84 + 2m \cdot 2$$

$$\Rightarrow m^2 - m = 84 + 4m$$

$$\Rightarrow m^2 - 5m - 84 = 0$$

$$\therefore m = 12 \text{ or } m = -7 \text{ (rejected).}$$

2. The mean and the variance of five observations are 4 and 5.20, respectively. If three of the observations are 3, 4 and 4, then the absolute value of the difference of the other two observations, is

(1*) 7 (2) 3 (3) 1 (4) 5

Sol. $4 = \frac{3+4+4+\alpha+\beta}{5} \Rightarrow \alpha + \beta = 9$

$$\text{and } \sigma^2 = 5 \cdot 2 = \frac{26}{5} = \frac{(3-4)^2 + 0 + 0 + (\alpha-4)^2 + (\beta-4)^2}{5}$$

$$\Rightarrow (\alpha-4)^2 + (\beta-4)^2 = 25$$

$$\Rightarrow a^2 + b^2 + 16 + 16 - 8 \cdot 9 = 25$$

$$\Rightarrow \alpha^2 + \beta^2 = 65$$

$$\therefore (\alpha + \beta)^2 = 81 = 65 + 2\alpha\beta \Rightarrow \alpha\beta = 8$$

$$\therefore (\alpha - \beta)^2 = 65 - 16 = 49$$

$$\therefore |\alpha - \beta| = 7.$$

3. In a game, a man wins Rs. 100 if he gets 5 or 6 on a throw of a fair die and loses Rs. 50 for getting any other number on the die. If he decides to throw the die either till he gets a five or a six or to a maximum of three throws, then his expected gain/loss (in rupees) is

(1) $\frac{400}{3}$ loss (2*) 0 (3) $\frac{400}{3}$ gain (4) $\frac{400}{9}$ loss

Sol. $P(5 \cup 6) = \frac{2}{6}$

$$P(5 \cup 6) = (x) \cup (x\checkmark) \cup (xx\checkmark) \cup (xxx)$$

$$= \frac{2}{6} \times 100 + \left(\frac{4}{6}\right) \frac{2}{6} \times (100 - 50) + \left(\frac{4}{6}\right) \left(\frac{4}{6}\right) \frac{2}{6} (-50 + 50 + 100) + \left(\frac{4}{6}\right) \left(\frac{4}{6}\right) \left(\frac{4}{6}\right) (-50 - 50 - 50) = 0.$$

4. The number of integral values of m for which the quadratic expression, $(1 + 2m)x^2 - 2(1 + 3m)x + 4(1 + m)$, $x \in \mathbb{R}$, is always positive, is
- (1) 8 (2) 3 (3) 6 (4*) 7

Sol. Expression is always positive if $2m + 1 > 0 \Rightarrow m > -\frac{1}{2}$

and $D < 0 \Rightarrow m^2 - 6m - 3 < 0$

\therefore Common interval is $3 - \sqrt{12} < m < 3 + \sqrt{12}$

\therefore Integral value of m $\{0, 1, 2, 3, 4, 5, 6\}$

5. Let S and S' be the foci of an ellipse and B be any one of the extremities of its minor axis. If $\Delta S'BS$ is a right angled triangle with right angle at B and area $\Delta S'BS = 8$ s units, then the length of a latus rectum of the ellipse is
- (1) $2\sqrt{2}$ (2*) 4 (3) $4\sqrt{2}$ (4) 2

Sol. $m_{SB} \cdot m_{S'B} = -1$

$\Rightarrow \frac{b}{-ae} \cdot \frac{b}{ae} = -1 \Rightarrow b^2 = a^2 e^2 \Rightarrow \frac{b^2}{a^2} = 1 - \frac{b^2}{a^2} \Rightarrow b^2 = \frac{a^2}{2}$

$\Rightarrow \frac{1}{2} (b^2 + a^2 e^2) = 8 \Rightarrow b^2 = 8, a^2 = 16$

$\therefore L_{LR} = \frac{2b^2}{a} = \frac{2 \cdot 8}{4} = 4$.

6. The integral $\int \frac{3x^{13} + 2x^{11}}{(2x^4 + 3x^2 + 1)^4} dx$ is equal to
- (Where C is a constant of integration).
- (1) $\frac{x^4}{6(2x^4 + 3x^2 + 1)^3} + C$ (2) $\frac{x^{12}}{(2x^4 + 3x^2 + 1)^3} + C$
- (3) $\frac{x^4}{(2x^4 + 3x^2 + 1)^3} + C$ (4*) $\frac{x^{12}}{6(2x^4 + 3x^2 + 1)^3} + C$

Sol. $I = \int \frac{3x^{13} + 2x^{11}}{(2x^4 + 3x^2 + 1)^4} dx = \int \frac{x^{\frac{3}{2}} + x^{\frac{5}{2}}}{\left(2 + \frac{3}{x^2} + \frac{1}{x^4}\right)^4} dx = \frac{-1}{2} \int \frac{\left(\frac{-6}{x^3} - \frac{4}{x^5}\right)}{\left(2 + \frac{3}{x^2} + \frac{1}{x^4}\right)^4} dx$

$= \left(\frac{-1}{2}\right) \frac{\left(2 + \frac{3}{x^2} + \frac{1}{x^4}\right)^{-3}}{-3} + C = \frac{1}{6 \left(2 + \frac{3}{x^2} + \frac{1}{x^4}\right)^3} + C = \frac{x^{12}}{6(2x^4 + 3x^2 + 1)^3} + C$.

7. Let Z be the set of integers. If $A = \{x \in Z : \dots\}$ and $B = \{x \in Z : 2^{(x+2)(x^2-5x+6)} = 1 - 3 < 2x - 1 < 9\}$, then the number of subsets of the set $A \times B$, is

- (1) 2^{12} (2) 2^{10} (3*) 2^{15} (4) 2^{18}

Sol. $a = \left\{ x \in \mathbb{Z} : 2^{(x+2)(x^2-5x+6)} = 1 \right\}$

$$2^{(x+2)(x^2-5x+6)} = 2^0 \Rightarrow x = -2, 2, 3$$

$$A = \{-2, 2, 3\}$$

$$B = \{x \in \mathbb{Z} : -3 < 2x - 1 < 9\}$$

$$B = \{0, 1, 2, 3, 4\}$$

Hence, $A \times B$ has 15 elements.

So number of subsets of $A \times B$ is 2^{15} .

8. If the function f given by $f(x) = x^3 - 3(a-2)x^2 + 3ax + 7$, for some $a \in \mathbb{R}$ is increasing in $(0, 1]$ and decreasing in $[1, 5)$, then a root of the equation, $\frac{f(x)-14}{(x-1)^2} = 0 (x \neq 1)$ is

- (1*) 7 (2) -7 (3) 6 (4) 5

Sol. $f'(x) = 3x^2 - 6(a-2)x + 3a$

$$\therefore f'(1) = 3 - 6a + 12 + 3a = 15 - 3a = 0 \Rightarrow a = 5$$

$$\therefore f(x) = x^3 - 9x^2 + 15x + 7 = 14$$

$$\therefore x^3 - 9x^2 + 15x - 7 = 0 \Rightarrow (x-1)(x^2 - 8x + 7) = 0$$

$$\Rightarrow (x-1)(x-1)(x-7) = 0$$

$$\Rightarrow x = 7.$$

9. The tangent to the curve $y = x^2 - 5x + 5$, parallel to the line $2y = 4x + 1$, also passes through the point

- (1*) $\left(\frac{1}{8}, -7\right)$ (2) $\left(\frac{1}{4}, \frac{7}{2}\right)$ (3) $\left(\frac{-1}{8}, 7\right)$ (4) $\left(\frac{7}{2}, \frac{1}{4}\right)$

Sol. $\frac{dy}{dx} = 2x - 5 \Rightarrow x = \frac{7}{2}$ and $y = \frac{-1}{4}$

$$\therefore T : \left(y + \frac{1}{4}\right) = 2\left(x - \frac{7}{2}\right) = 2x - 7$$

$$\Rightarrow y = 2x - \frac{29}{4} \Rightarrow 4y = 8x - 29.$$

10. If the angle of elevation of a cloud from a point P which is 25m above a lake be 30° and the angle of depression of reflection of the cloud in the lake from P be 60° , then the height of the cloud (in meters) from the surface of the lake is

- (1) 45 (2) 42 (3) 60 (4*) 50

Sol. $\tan 30^\circ = \frac{1}{\sqrt{3}} = \frac{H-25}{L}$ and $\tan 60^\circ = \sqrt{3} = \frac{H+25}{L}$

$$(\pm) \frac{1}{3} = \frac{H-25}{H+25}$$

$$\therefore H + 25 = 3H - 75 \Rightarrow 2H = 100 \Rightarrow H = 50.]$$

11. If an angle between the line, $\frac{x+1}{2} = \frac{y-2}{1} = \frac{z-3}{-2}$ and the plane, $x - 2y - kz = 3$ is $\cos^{-1}\left(\frac{2\sqrt{2}}{3}\right)$, then a value of k, is

(1) $\frac{-3}{5}$ (2*) $\sqrt{\frac{5}{3}}$ (3) $\sqrt{\frac{3}{5}}$ (4) $\frac{-5}{3}$

Sol. $\vec{l} \langle 2 \ 1 \ -1 \rangle$ and $\vec{n} \langle 1 \ -2 \ -k \rangle$

$$\sin \theta = \left| \frac{2 - 2 + 2k}{3\sqrt{k^2 + 5}} \right| = \frac{1}{3}$$

$$\Rightarrow |2k| = \sqrt{k^2 + 5} \Rightarrow 3k^2 = 5 \Rightarrow k = \pm \sqrt{\frac{5}{3}}$$

12. In a class of 60 students, 40 opted for NCC, 30 opted for NSS and 20 opted for both NCC and NSS. If one of these students is selected at random, then the probability that the students selected has opted neither for NCC nor for NSS is

(1*) $\frac{1}{6}$ (2) $\frac{2}{3}$ (3) $\frac{5}{6}$ (4) $\frac{1}{3}$

Sol. $n(U) = 60, n(C) = 40, n(S) = 30, n(C \cap S) = 20$

$$= P(\bar{C} \cap \bar{S}) = 1 - P(C \cup S) = 1 - \left(\frac{40 + 30 - 20}{60}\right) = 1 - \frac{5}{6} = \frac{1}{6}.$$

13. Let f be a differentiable function such that $f(1) = 2$ and $f'(x) = f(x)$ for all $x \in \mathbb{R}$. If $h(x) = f(f(x))$, then $h'(1)$ is equal to

(1) $2e$ (2) $4e^2$ (3) $2e^2$ (4*) $4e$

Sol. $f'(x) = f(x) \Rightarrow \frac{dy}{dx} = y \Rightarrow \ln y = x + c$

$$\therefore y = \lambda e^x \Rightarrow f(1) = 2$$

$$\therefore 2 = \lambda e \Rightarrow \lambda = \frac{2}{e}$$

$$\therefore y = \frac{2e^x}{e}$$

$$\therefore h(x) = f(f(x)) = f\left(\frac{2e^x}{e}\right) = \frac{2e^{\frac{2e^x}{e}}}{e}$$

$$\therefore h'(x) = \frac{2e^{\frac{2x}{e}}}{e} \cdot \frac{2e^x}{e} = \frac{4}{e^2} \cdot e^{\frac{2x}{e}} \cdot e^x$$

$$\therefore h'(1) = \frac{4}{e^2} \cdot e^2 \cdot e = 4e.$$

14. If a straight line passing through the point P(-3, 4) is such that its intercepted portion between the coordinate axes is bisected at P, then its equation is

(1) $4x + 3y = 0$ (2) $x - y + 7 = 0$ (3) $3x - 4y + 25 = 0$ (4*) $4x - 3y + 24 = 0$

Sol. Let the line be $\frac{x}{a} + \frac{y}{b} = 1$

$$(-3, 4) = \left(\frac{a}{2}, \frac{b}{2}\right)$$

$$a = -6, b = 8$$

$$4x - 3y + 24 = 0$$

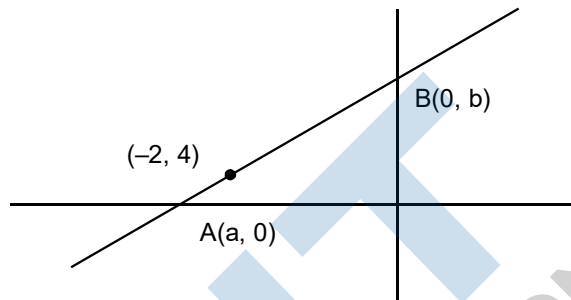

15. If $\sin^4 \alpha + 4\cos^4 \beta + 2 = 4\sqrt{2} \sin \alpha \cos \beta$; $\alpha, \beta \in [0, \pi]$, then $\cos(\alpha + \beta) - \cos(\alpha - \beta)$ is equal to

(1) $\sqrt{2}$ (2*) $-\sqrt{2}$ (3) 0 (4) -1

Sol. A.M. \geq G.M.

$$\frac{\sin^4 \alpha + 4\cos^4 \beta + 1 + 1}{4} \geq (\sin^4 \alpha \cdot 4\cos^4 \beta \cdot 1 \cdot 1)^{\frac{1}{4}}$$

$$\sin^4 \alpha + 4\cos^4 \beta + 2 \geq 4\sqrt{2} \sin \alpha \cos \beta \text{ given that } \sin^4 \alpha + 4\cos^4 \beta + 2 = 4\sqrt{2} \sin \alpha \cos \beta$$

$$\Rightarrow \text{A.M.} = \text{G.M.} \Rightarrow \sin^4 \alpha = 1 = 4\cos^4 \beta$$

$$\sin \alpha = \pm 1, \cos \beta = \pm \frac{1}{\sqrt{2}}, \text{As } \alpha, \beta \in [0, \pi]$$

$$\Rightarrow \sin \alpha = 1, \cos \beta = \pm \frac{1}{\sqrt{2}}$$

$$\Rightarrow \sin \beta = \frac{1}{\sqrt{2}} \text{ as } \beta \in [0, \pi]$$

$$\cos(\alpha + \beta) - \cos(\alpha - \beta) = -2 \sin \alpha \sin \beta$$

$$= -\sqrt{2}$$

16. Let \vec{a}, \vec{b} and \vec{c} be three vectors, out of which vectors \vec{b} and \vec{c} are non-parallel. If α and β are the angles which vectors \vec{a} makes with vectors \vec{b} and \vec{c} respectively and $\vec{a} \times (\vec{b} \times \vec{c}) = \frac{1}{2}\vec{b}$, then $|\alpha - \beta|$ is equal to

(1) 90° (2) 60° (3) 45° (4*) 30°

Sol. $[\vec{a} \cdot \vec{c}]\vec{b} - (\vec{a} \cdot \vec{b})\vec{c} = \frac{\vec{b}}{2} + 0 \cdot \vec{c}$

$$\therefore \vec{a} \cdot \vec{c} = \frac{1}{2} = 0 \Rightarrow \cos \beta \frac{1}{2} \Rightarrow \beta = 60^\circ$$

$$\text{and } \vec{a} \cdot \vec{b} = 0 \Rightarrow \alpha = 90^\circ.$$

17. The integral $\int_1^e \left\{ \left(\frac{x}{e} \right)^{2x} - \left(\frac{e}{x} \right)^x \right\} \log_e x \, dx$ is equal to

- (1) $\frac{1}{2} - e - \frac{1}{e^2}$ (2*) $\frac{3}{2} - e - \frac{1}{2e^2}$ (3) $\frac{3}{2} - \frac{1}{e} - \frac{1}{2e^2}$ (4) $-\frac{1}{2} + \frac{1}{e} - \frac{1}{2e^2}$

Sol. $I = \int_1^e \left\{ \left(\frac{x}{e} \right)^{2x} - \left(\frac{e}{x} \right)^x \right\} \log_e x \, dx$

$$I = \int_1^e \left(\frac{x}{e} \right)^{2x} \cdot \ln x \, dx - \int_1^e \left(\frac{e}{x} \right)^x \cdot \ln x \, dx$$

$$I_1 = \frac{1}{2} \int_1^e \left(\frac{x}{e} \right)^{2x} \cdot 2 \ln x \, dx$$

$$\text{let } \left(\frac{x}{e} \right)^{2x} = t$$

$$I_1 = \frac{1}{2} \int dt \Rightarrow I_1 = \frac{1}{2} \left[\left(\frac{x}{e} \right)^{2x} \right]_1^e = \frac{1}{2} \left(1 - \frac{1}{e^2} \right)$$

$$I_2 = - \int_1^e \left(\frac{e}{x} \right)^x \cdot \ln x \, dx$$

$$\text{let } \left(\frac{e}{x} \right)^x = s$$

$$I_2 = - \int ds = \left[\left(\frac{e}{x} \right)^x \right]_1^e = -(1 - e) = e - 1$$

$$\therefore I = \frac{1}{2} - \frac{1}{2e^2} - e + 1 = \frac{3}{2} - e - \frac{1}{2e^2}$$

18. The expression $\sim (\sim p \rightarrow q)$ is logically equivalent to

- (1*) $\sim p \wedge \sim q$ (2) $p \wedge \sim q$ (3) $\sim p \wedge q$ (4) $p \wedge q$

Sol. $(p \rightarrow q) \equiv (\sim p \vee q)$

$$\therefore \sim p \rightarrow q \equiv p \vee q$$

$$\therefore \sim (p \vee q) = \sim p \wedge \sim q$$

19. The set of all values of λ for which the system of linear equations

$$x - 2y - 2z = \lambda x$$

$$x + 2y + z = \lambda y$$

$$-x - y = \lambda z$$

has a non-trivial solution

(1*) is a singleton

(2) is an empty set

(3) contains more than two elements

(4) contains exactly two elements

Sol.
$$\Delta = \begin{vmatrix} 1-\lambda & -2 & -2 \\ 1 & 2-\lambda & 1 \\ -1 & -1 & -\lambda \end{vmatrix} = 0$$

$$\Rightarrow \begin{vmatrix} 3-\lambda & 0 & -2 \\ \lambda-1 & 1-\lambda & 1 \\ 0 & \lambda-1 & -\lambda \end{vmatrix} = 0$$

$$\Rightarrow (\lambda-1) \begin{vmatrix} 3-\lambda & 0 & -2 \\ \lambda-1 & -1 & 1 \\ 0 & 1 & -\lambda \end{vmatrix} = 0$$

$$\Rightarrow (\lambda-1) ((3-\lambda)(\lambda-1) - 2(\lambda-1)) = 0$$

$$\Rightarrow (\lambda-1)^2 (3-\lambda-2) = 0 \Rightarrow (\lambda-1)^2 (1-\lambda) = 0 \Rightarrow \lambda = 1.$$

20. $\lim_{x \rightarrow 1^-} \frac{\sqrt{\pi} - \sqrt{2\sin^{-1}x}}{\sqrt{1-x}}$ is equal to

- (1) $\sqrt{\frac{\pi}{2}}$ (2) $\sqrt{\pi}$ (3) $\frac{1}{\sqrt{2\pi}}$ (4*) $\sqrt{\frac{2}{\pi}}$

Sol. Let $\sin^{-1}x = t$

$$\begin{aligned} \lim_{t \rightarrow (\frac{\pi}{2})^-} \frac{\sqrt{\pi} - \sqrt{2t}}{\sqrt{1-\sin t}} &= \lim_{t \rightarrow (\frac{\pi}{2})^-} \frac{\pi - 2t}{\sqrt{\pi + \sqrt{2t}}} \cdot \frac{\sqrt{1+\sin t}}{\cos t} \\ &= \frac{\sqrt{2}}{2\sqrt{\pi}} \lim_{t \rightarrow (\frac{\pi}{2})^-} \frac{\pi - 2t}{\cos t} = \frac{1}{\sqrt{2\pi}} \lim_{t \rightarrow (\frac{\pi}{2})^-} \frac{-2}{-\sin t} = \frac{2}{\sqrt{2\pi}} = \sqrt{\frac{2}{\pi}} \end{aligned}$$

21. Let z_1 and z_2 be two complex numbers satisfying $|z_1| = 9$ and $|z_2 - 3 - 4i| = 4$. Then the minimum value of $|z_1 - z_2|$, is

- (1) $\sqrt{2}$ (2) 2 (3*) 0 (4) 1

Sol. \therefore Minimum = 0.

22. The equation of a tangent to the parabola, $x^2 = 8y$, which makes an angle θ with the positive direction of x-axis, is

- (1*) $x = y \cot\theta + 2 \tan\theta$ (2) $y = x \tan\theta + 2 \cot\theta$
 (3) $y = x \tan\theta - 2 \cot\theta$ (4) $x = y \cot\theta - 2 \tan\theta$

Sol. T : $y = \tan \theta \cdot x + c$

$$P : x^2 = 8(\tan \theta \cdot x + c)$$

$$\therefore x^2 - 8\tan\theta - 8c = 0$$

$$\Delta = 64\tan^2\theta + 32c = 0$$

$$\Rightarrow c = -2\tan^2\theta$$

$$\therefore T : y = x\tan\theta - 2\tan^2\theta$$

$$\Rightarrow y\cot\theta = x - 2\tan\theta.$$

23. If $A = \begin{bmatrix} 1 & \sin\theta & 1 \\ -\sin\theta & 1 & \sin\theta \\ -1 & -\sin\theta & 1 \end{bmatrix}$; then for all $\theta \in \left(\frac{3\pi}{4}, \frac{5\pi}{4}\right)$, $\det(A)$ lies in the interval

- (1) $\left(1, \frac{5}{2}\right]$ (2) $\left[\frac{5}{2}, 4\right)$ (3) $\left(0, \frac{3}{2}\right]$ (4*) $\left(\frac{3}{2}, 3\right]$

Sol. $\Delta = 2(1 + \sin^2\theta)$

$$\therefore \sin^2\theta \in \left(0, \frac{1}{2}\right)$$

$$\therefore 1 + \sin^2\theta \in \left(1, \frac{3}{2}\right)$$

$$\Delta \in (2, 3).$$

24. $\lim_{n \rightarrow \infty} \left(\frac{n}{n^2 + 1^2} + \frac{n}{n^2 + 2^2} + \frac{n}{n^2 + 3^2} + \dots + \frac{1}{5n} \right)$ is equal to

- (1) $\tan^{-1}(3)$ (2) $\frac{\pi}{2}$ (3) $\frac{\pi}{4}$ (4*) $\tan^{-1}(2)$

Sol. $\lim_{n \rightarrow \infty} \sum_{r=1}^{2n} \frac{n}{n^2 + r^2} = \lim_{n \rightarrow \infty} \frac{1}{n} \sum_{r=1}^{2n} \frac{1}{1 + \left(\frac{r}{n}\right)^2} = \int_0^2 \frac{dx}{1 + x^2} = \tan^{-1}(2).$

25. If a circle of radius R passes through the origin O and intersect the coordinate axes at A and B, then the locus of the foot of the perpendicular from O on AB is

- (1) $(x^2 + y^2)(x + y) = R^2xy$ (2) $(x^2 + y^2)^2 = 4R^2x^2y^2$
 (3) $(x^2 + y^2)^2 = 4R^2x^2y^2$ (4*) $(x^2 + y^2)^3 = 4R^2x^2y^2$

Sol. Slope of AB = $\frac{-h}{k}$

Equation of AB is $hx + ky = h^2 + k^2$

$$A\left(\frac{h^2 + k^2}{h}, 0\right), B\left(0, \frac{h^2 + k^2}{k}\right)$$

As, $AB = 2R$

$$\Rightarrow (h^2 + k^2)^3 = 4R^2h^2k^2$$

$$\Rightarrow (x^2 + y^2)^3 = 4R^2x^2y^2$$

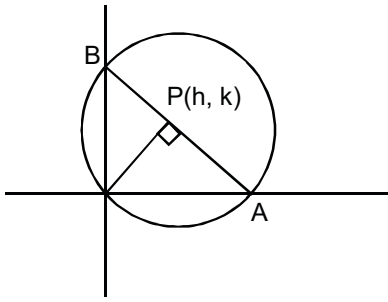

26. If a curve passes through the point $(1, -2)$ and has slope of the tangent at any point (x, y) on it as $\frac{x^2 - 2y}{x}$, then the curve also passes through the point

- (1*) $(\sqrt{3}, 0)$ (2) $(-1, 2)$ (3) $(3, 0)$ (4) $(-\sqrt{2}, 1)$

Sol. $\frac{dy}{dx} = x - \frac{2y}{x} \Rightarrow \frac{dy}{dx} + \frac{2y}{x} = x$

\therefore I.F. = $e^{\int \frac{2}{x} dx} = x^2$

$\therefore yx^2 = \int x^2 \cdot x dx = \frac{x^4}{4} + C$

$(1, -2) \Rightarrow -2 = \frac{1}{4} + C \Rightarrow C = -2 - \frac{1}{4} = -\frac{9}{4}$

$\therefore yx^2 = \frac{x^4}{4} - \frac{9}{4} \Rightarrow 4x^2y = x^4 - 9$.]

27. Let S be the set of all real values of λ such that a plane passing through the point $(-\lambda^2, 1, 1)$, and $(1, 1, -\lambda^2)$, $(1, -\lambda^2, 1)$ also passes through the point $(-1, -1, 1)$. Then S is equal to

- (1) $\{\sqrt{3}\}$ (2*) $\{\sqrt{3}, -\sqrt{3}\}$ (3) $\{1, -1\}$ (4) $\{3, -3\}$

Sol. $[\bar{a} - \bar{d} \quad \bar{b} - \bar{d} \quad \bar{c} - \bar{d}] = 0$

$$\begin{vmatrix} 1-\lambda^2 & 2 & 0 \\ 2 & 1-\lambda^2 & 0 \\ 2 & 2 & -\lambda^2-1 \end{vmatrix} = 0$$

$\Rightarrow (\lambda^2 + 1) ((1-\lambda^2)^2 - 4) = 0$

$\Rightarrow 1 - \lambda^2 = \pm 2 \Rightarrow \lambda^2 = 1 \pm 2 \Rightarrow \lambda^2 = -1$ or 3

$\Rightarrow \lambda = \pm \sqrt{3}$

28. The total number of irrational terms in the binomial expansion of $(7^{1/5} - 3^{1/10})^{60}$ is

- (1) 48 (2*) 54 (3) 55 (4) 49

Sol. General term $T_{r+1} = {}^{60}C_r \cdot 7^{\frac{60-r}{5}} \cdot 3^{\frac{r}{10}}$
 \therefore for rational term, $r = 0, 10, 20, 30, 40, 50, 60$
 \Rightarrow number of rational terms = 7
 \therefore number of irrational terms = 54

29. If ${}^nC_4, {}^nC_5$ and nC_6 are in A.P., then n can be
 (1) 11 (2) 12 (3) 9 (4*) 14

Sol. $2 \cdot {}^nC_5 = {}^nC_4 + {}^nC_6$
 $2 \cdot \frac{n!}{5!n-5!} = \frac{n!}{4!n-4!} + \frac{n!}{6!n-6!}$
 $\frac{2}{5} \cdot \frac{1}{n-5} = \frac{1}{(n-4)(n-5)} + \frac{1}{30}$
 N = 14 satisfying equation.

30. If the sum of the first 15 terms of the series $\left(\frac{3}{4}\right)^3 + \left(1\frac{1}{2}\right)^3 + \left(2\frac{1}{4}\right)^3 + 3^3 + \left(3\frac{3}{4}\right)^3 + \dots$ is equal to 225k, then k is equal to
 (1*) 27 (2) 108 (3) 54 (4) 9

Sol. $S = \left(\frac{3}{4}\right)^3 + \left(\frac{6}{4}\right)^3 + \left(\frac{9}{4}\right)^3 + \left(\frac{12}{4}\right)^3 + \dots 15 \text{ term}$
 $= \frac{27}{64} \sum_{r=1}^{15} r^3$
 $= \frac{27}{64} \cdot \left[\frac{15(15+1)}{2}\right]^2$
 $= 225 K$ (gives in question)
 K = 27

PART-B-CHEMISTRY

31. The major product of the following reaction is:

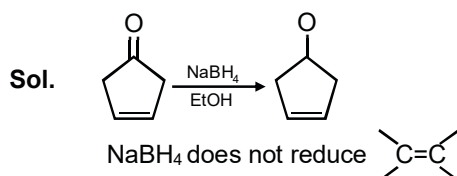
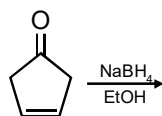

32. For a reaction, consider the plot of $\ln k$ versus $1/T$ given in the figure. If the rate constant of this reaction at 400 K is 10^{-5} s^{-1} , then the rate constant at 500 K is :

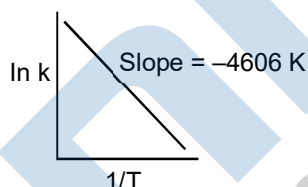

- (1*) 10^{-4} s^{-1} (2) $4 \times 10^{-4} \text{ s}^{-1}$ (3) $2 \times 10^{-4} \text{ s}^{-1}$ (4) 10^{-6} s^{-1}

Sol. $K = Ae^{-\frac{E_a}{RT}}$

$$\ln K = \ln A - \frac{E_a}{RT}$$

Slope of $\ln K$ v/s $\frac{1}{T}$ is $-\frac{E_a}{R}$

$$-\frac{E_a}{R} = -4606$$

$$\frac{E_a}{R} = 4606$$

$$\ln\left(\frac{K_2}{K_1}\right) = \frac{E_a}{R} \left(\frac{1}{T_1} - \frac{1}{T_2}\right)$$

$$= 4606 \left(\frac{1}{400} - \frac{1}{500}\right)$$

$$\ln\left(\frac{K_2}{K_1}\right) = 2.303$$

$$\frac{K_2}{K_1} = 10$$

$$K_2 = 10 K_1$$

$$K_2 = 10 \times 10^{-5} = 10^{-4} \text{ s}^{-1}$$

33. The increasing order of the reactivity of the following with LiAlH_4 is :

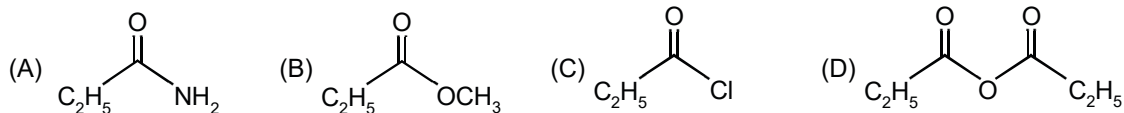

(1*) (A) < (B) < (D) < (C)

(2) (A) < (B) < (C) < (D)

(3) (B) < (A) < (D) < (C)

(4) (B) < (A) < (C) < (D)

Sol. The order is identical to nucleophilic substitution order:

Acid chloride > Acid anhydride > Acid > Amide

34. The correct order of atomic radii is:

(A) $\text{Nd} > \text{Ce} > \text{Eu} > \text{Ho}$

(B) $\text{Ho} > \text{Nd} > \text{Eu} > \text{Ce}$

(C) $\text{Ce} > \text{Eu} > \text{Ho} > \text{Nd}$

(D*) $\text{Eu} > \text{Ce} > \text{Nd} > \text{Ho}$

Sol. The atomic radii are

$\text{Eu} = 199 \text{ pm}$

$\text{Ce} = 183 \text{ pm}$

$\text{Nd} = 181 \text{ pm}$

$\text{Ho} = 176 \text{ pm}$

35. The element that does NOT show catenation is:

(1) Ge

(2) Si

(3) Sn

(4*) Pb

Sol. Due to the lowest bond energy of Pb – Pb bond.

36. The major product of the following reaction is:

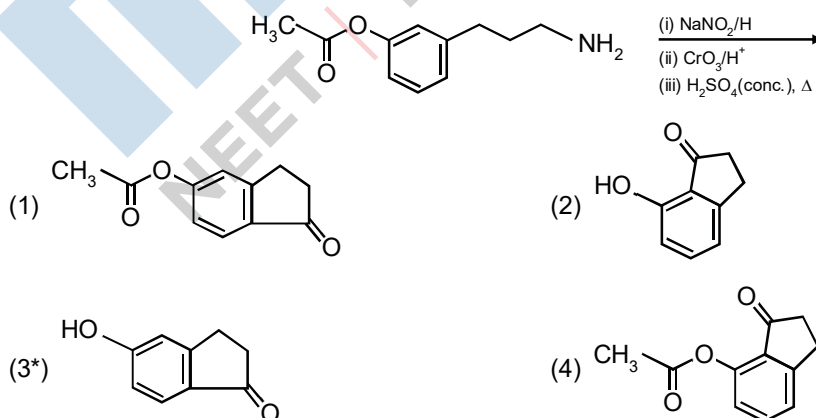

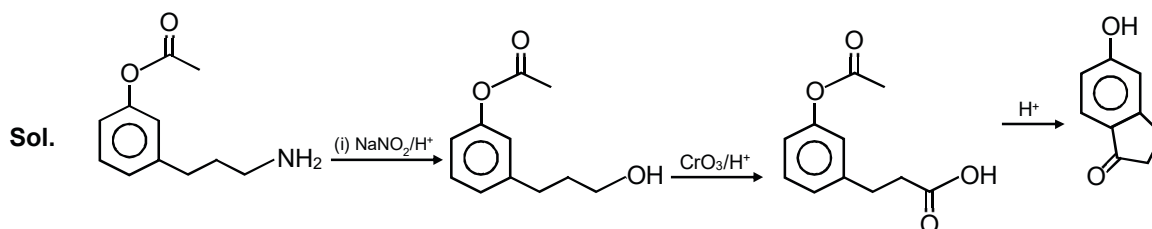

37. The correct statement(s) among I to III with respect to potassium ions that are abundant within the cell fluids is/are:

- (I) They activate many enzymes
 (II) They participate in the oxidation of glucose to produce ATP
 (III) Along with sodium ions, they are responsible for the transmission of nerve signals

- (1) I and II only (2) I, II and III (3*) III only (4) I and III only

Sol. Active transport proteins exchange Na^+ ions for K^+ ions across the plasma membrane of animal cells.

38. The major product in the following conversion is:

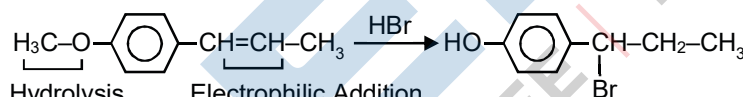
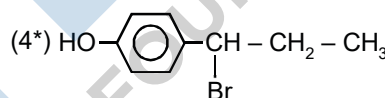
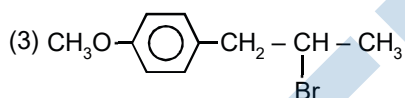
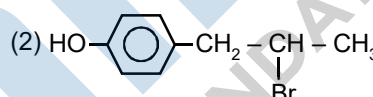
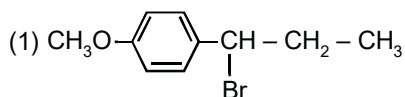
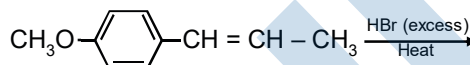

Sol. Hydrolysis of ether Electrophilic Addition
 Acc. To markonikoff's Rule

39. The pair that does NOT require calcination is :

- (1) Fe_2O_3 and $\text{CaCO}_3 \cdot \text{MgCO}_3$ (2) ZnO and $\text{Fe}_2\text{O}_3 \cdot x\text{H}_2\text{O}$
 (3*) ZnO and MgO (4) ZnCO_3 and CaO

Sol. In calcination the ore is converted to metal oxide. ZnO and MgO are already in oxide form.

40. The magnetic moment of an octahedral homoleptic Mn(II) complex is 5.9 BM. The suitable ligand for this complex is :

- (1) CO (2) ethylenediamine (3*) NCS^- (4) CN^-

Sol. Homoleptic complexes contain identical ligands, e.g., $[\text{Mn}(\text{NCS})_6]^{4-}$.

41. Chlorine on reaction with hot and concentrated sodium hydroxide gives :

(1*) Cl^- and ClO_3^- (2) Cl^- and ClO^- (3) Cl^- and ClO_2^- (4) ClO_3^- and ClO_2^-

Sol. $6\text{NaOH} + \text{Cl}_2 \longrightarrow 5\text{NaCl} + \text{NaClO}_3 + 3\text{H}_2\text{O}$.

42. Molecules of benzoic acid ($\text{C}_6\text{H}_5\text{COOH}$) dimerise in benzene. 'w' g of the acid dissolved in 30 g of benzene shows a depression in freezing point equal to 2 K. If the percentage association of the acid to form dimer in the solution is 80, then w is:

[Given that $K_f = 5 \text{ K kg mol}^{-1}$, Molar mass of benzoic acid = 122 g mol^{-1}]

(1) 1.8 g (2*) 2.4 g (3) 1.0 g (4) 1.5 g

Sol. $\Delta T_f = K_f \cdot m \cdot i$

$$2 = 5 \cdot \frac{w / 122}{30} \times 1000 \times \left\{ 1 + 0.8 \left(\frac{1}{2} - 1 \right) \right\}$$

$$w = 2.4 \text{ g}$$

43. Λ_m° for NaCl, HCl and NaA are 126.4, 425.9 and $100.5 \text{ S cm}^2 \text{ mol}^{-1}$, respectively. If the conductivity of 0.001 M HA is $5 \times 10^{-5} \text{ S cm}^{-1}$, degree of dissociation of HA is :

(1) 0.25 (2*) 0.125 (3) 0.75 (4) 0.50

Sol. $\alpha = \frac{\Lambda_m(\text{HA})}{\Lambda_m^\circ(\text{HA})}$

$$\Lambda_m^\circ(\text{HA}) = \Lambda_m^\circ(\text{HCl}) + \Lambda_m^\circ(\text{NaA}) - \Lambda_m^\circ(\text{NaCl})$$

$$= 425.9 + 100.5 - 125.4$$

$$= 400$$

$$= \Lambda_m(\text{HA}) = \frac{K \times 100}{M} = \frac{5 \times 10^{-5} \times 1000}{0.001} = 50$$

$$\alpha = \frac{50}{400} = 0.125$$

44. The aldehydes which will not form Grignard product with one equivalent Grignard reagents are :

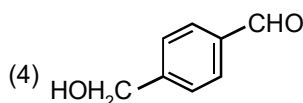
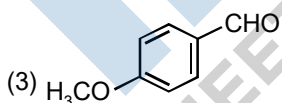
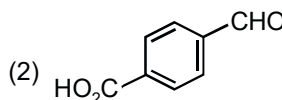
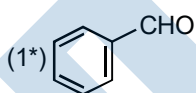

Sol. Each of (b) and (d) will react two moles of Grignard reagent.

45. Among the following, the false statement is :

(1) Tyndall effect can be used to distinguish between a colloidal solution and a true solution.

(2) It is possible to cause artificial rain by throwing electrified sand carrying charge opposite to the one on clouds from an aeroplane.

(3*) Lyophilic sol can be coagulated by adding an electrolyte

(4) Latex is a colloidal solution of rubber particles which are positively charged

Sol. Theory based

46. The upper stratosphere consisting of the ozone layer protects us from the sun's radiation that falls in the wavelength region of :

- (1) 600 – 750 nm (2*) 200 – 315 nm (3) 400 – 550 nm (4) 0.8 – 1.5 nm

Sol. In ozone layer the wavelength of U.V radiation is 200 – 340 nm.

47. The element that shows greater ability to form $p\pi - p\pi$ multiple bonds, is :

- (1) Sn (2) Si (3) Ge (4*) C

Sol. It is due to the smallest atomic size of carbon in the given options.

48. The volume strength of 1 M H_2O_2 is : (Molar mass of $H_2O_2 = 34 \text{ g mol}^{-1}$)

- (1) 22.4 (2*) 11.35 (3) 16.8 (4) 5.6

Sol. $M = \frac{\text{volumestrengthof } H_2O_2}{11.35}$

Volume strength = 1×11.35

Volume strength = 11.35

49. The major product of the following reaction is :

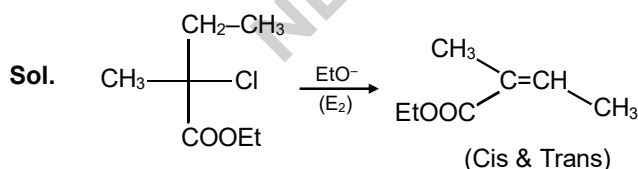
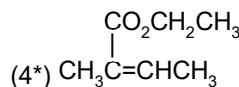
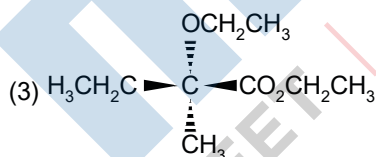
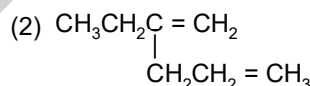
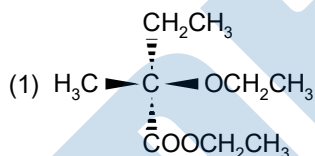
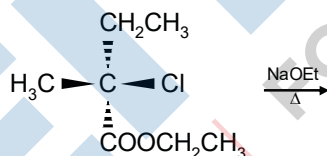

50. An open vessel at 27°C is heated until two fifth of the air (assumed as an ideal gas) in it has escaped from the vessel. Assuming that the volume of the vessel remains constant, the temperature at which the vessel has been heated is :

- (1) 750 °C (2) 750 K (3) 500 °C (4*) 500 K

Sol. In an open vessel

$$n_1 T_1 = n_2 T_2$$

$$(n) (300) = \left(n - \frac{2}{5}n \right) (T_2)$$

$$T_2 = 500 \text{ K}$$

51. 8 g of NaOH is dissolved in 18 g of H₂O. Mole fraction of NaOH in solution and molality (in mol kg⁻¹) of the solution respectively are :

- (1*) 0.167, 11.11 (2) 0.2, 11.11 (3) 0.167, 22.20 (4) 0.2, 22.20

Sol.
$$X_{\text{NaOH}} = \frac{n_{\text{NaOH}}}{n_{\text{NaOH}} + n_{\text{H}_2\text{O}}}$$

$$n_{\text{NaOH}} = \frac{8}{40} = 0.2$$

$$n_{\text{H}_2\text{O}} = \frac{18}{18} = 1$$

$$X_{\text{NaOH}} = \frac{0.2}{0.2+1} = 0.167$$

$$m = \frac{0.2}{18} \times 1000$$

$$m = \frac{200}{18} = 11.11$$

52. The combination of plots which does not represent isothermal expansion of an ideal gas is :

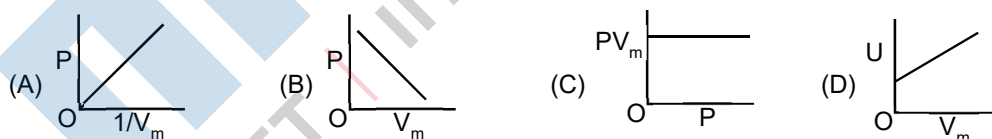

- (1) (B) and (D) (2) (A) and (D) (3*) (A) and (C) (4) (B) and (C)

Sol. During isothermal expansion of an ideal - gas

$$PV_m = \text{constant}$$

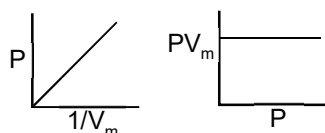

53. The two monomers for the synthesis of Nylon 6, 6 are

- (1) HOOC(CH₂)₄COOH, H₂N(CH₂)₄NH₂



Sol. The monomers are hexamethylene diamine and adipic acid.

54. If K_{sp} of Ag_2CO_3 is 8×10^{-12} , the molar solubility of Ag_2CO_3 in 0.1 M AgNO_3 is :

- (1) 8×10^{-13} M (2) 8×10^{-12} M (3*) 8×10^{-10} M (4) 8×10^{-11} M

Sol. Let solubility of $\text{Ag}_2\text{CO}_3 = 5 \text{ mol/L}$



0.1

— 0.1 0.1

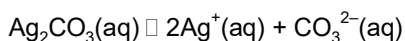

— S

2S + 0.1

$$K_{sp} = [\text{Ag}^+]^2 [\text{CO}_3^{2-}]$$

$$8 \times 10^{-12} = (2S + 0.1)^2 (S)^1$$

$$8 \times 10^{-12} = 10^{-2} (S)$$

$$S = 8 \times 10^{-10} \text{M}$$

55. The compound that is NOT a common component of photochemical smog is :

- (1*) O_3 (2) $\text{CH}_2=\text{CHCHO}$ (3) CF_2Cl_2 (4) $\text{H}_3\text{C}-\overset{\text{O}}{\parallel}{\text{C}}-\text{OONO}_2$

Sol. O_3 is not common component of London and Los Angeles smog. It is present only in Los Angeles smog

56. If the de Broglie wavelength of the electron in n^{th} Bohr orbit in a hydrogenic atom is equal to $1.5 \pi a_0$ (a_0 is Bohr radius), then the value of n / z is :

- (1) 0.40 (2) 1.50 (3) 1.0 (4*) 0.75

Sol. $2\pi r = n\lambda$

$$\lambda = \frac{2\pi r}{n}$$

$$1.5 \pi a_0 = \frac{2\pi \left(0.529 \times \frac{n^2}{Z} \right)}{n}$$

$$\frac{n}{Z} = \frac{1.5}{2} = 0.75$$

57. The major product of the following reaction is :

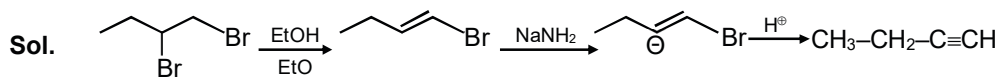
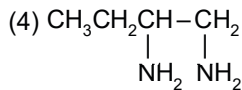
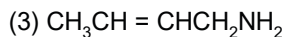
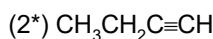
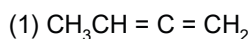
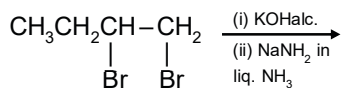

58. The correct structure of histidine in a strongly acidic solution (pH = 2) is :

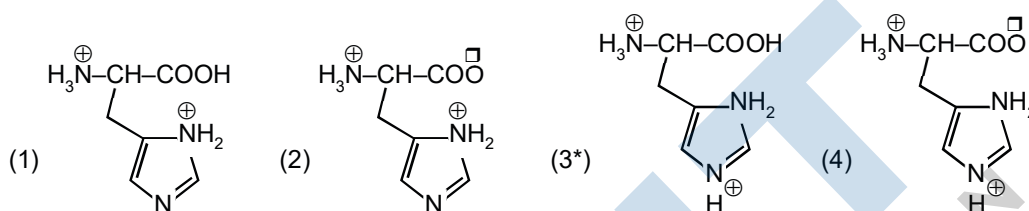

Sol. The COO^- group absorbs H^+ in acidic medium (pH = 2)

59. The major product of the following reaction is :

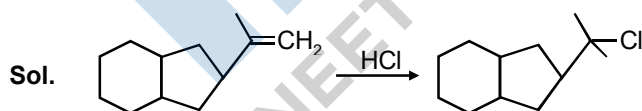
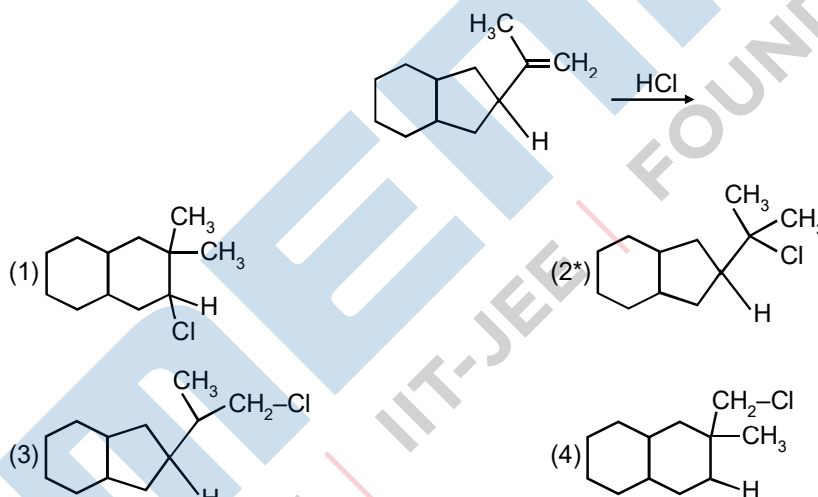

60. Given :

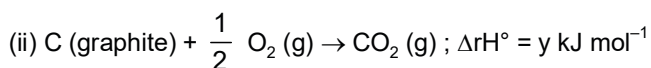
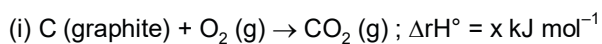

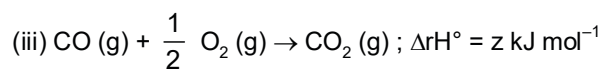

Based on the above thermochemical equations, find out which one of the following algebraic relationships is correct ?

$$(1) z = x + y$$

$$(2) x = y - z$$

$$(3) y = 2z - x$$

$$(4^*) x = y + z$$

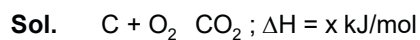

....(i)

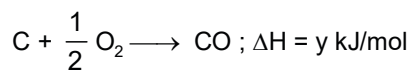

....(ii)

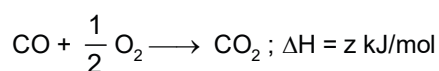

....(iii)

$$(i) = (ii) + (iii)$$

$$x = y + z$$

MENIIT
NEET | IIT-JEE | FOUNDATION

PART-C-PHYSICS

61. A Parallel plate capacitor with plates of area 1 m^2 each, are at a separation of 0.1 m . If the electric field between the plates is 100 N/C , then magnitude of charge on each plate is :

(Take $\epsilon_0 = 8.85 \times 10^{-12} \frac{\text{C}^2}{\text{N-m}^2}$)

- (1) $7.85 \times 10^{-10} \text{ C}$ (2) $9.85 \times 10^{-10} \text{ C}$ (3) $6.85 \times 10^{-10} \text{ C}$ (4*) $8.85 \times 10^{-10} \text{ C}$

Sol. $E = \frac{q}{A\epsilon_0}$

$\Rightarrow q = EA\epsilon_0$

$\Rightarrow q = 100 \times 1 \times 8.85 \times 10^{-12}$

$\Rightarrow q = 8.85 \times 10^{-10} \text{ C}$

62. The moment of inertia of a solid sphere, about an axis parallel to its diameter and at a distance of x from it, is ' $I(x)$ '. Which one of the graphs represents the variation of $I(x)$ with x correctly?

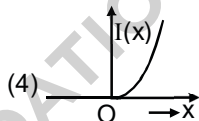
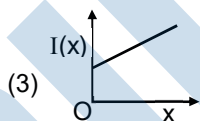
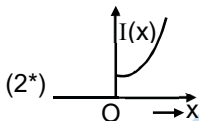
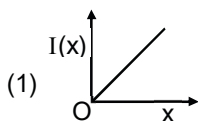

Sol. $I = I_{CM} + Mx^2$

$I_{CM} = \frac{2}{5}MR^2$

$I = \frac{2}{5}MR^2 + Mx^2$

63. In a Frank-Hertz experiment, an electron of energy 5.6 eV passes through mercury vapour and emerges with an energy 0.7 eV . The minimum wavelength of photons emitted by mercury atoms is closed to :

- (1) 1700 nm (2) 220 nm (3) 2020 nm (4*) 250 nm

Sol. $5.6\text{eV} - 0.7\text{eV} = 4.9\text{eV} = \frac{12410\text{eV} - \text{A}^\circ}{\lambda}$

$\lambda = \frac{12410\text{eV} - \text{A}^\circ}{4.9\text{eV}}$

$\approx 250 \text{ nm}$

64. An ideal gas is enclosed in a cylinder at pressure of 2 atm and temperature, 300 K . The mean time between two successive collisions is $6 \times 10^{-8} \text{ s}$. If the pressure is doubled and temperature is increased to 500 K , the mean time between two successive collisions will be close to :

- (1) $0.5 \times 10^{-8} \text{ s}$ (2) $3 \times 10^{-6} \text{ s}$ (3*) $4 \times 10^{-8} \text{ s}$ (4) $2 \times 10^{-7} \text{ s}$

Sol. The mean time between two collision $\propto \frac{P}{\sqrt{T}}$

$$\frac{\Delta t_1}{\Delta t_2} = \frac{P_1}{P_2} \times \frac{\sqrt{T_2}}{T_1}$$

$$\Rightarrow \frac{6 \times 10^{-8}}{\Delta t_2} = \left(\frac{\sqrt{3}}{\sqrt{5}}\right) \times 2$$

$$\Rightarrow \Delta t_2 = 6 \times 10^{-8} \times \frac{1}{2} \sqrt{\frac{3}{5}} \approx 4 \times 10^{-8} \text{ sec.}$$

65. To double the covering range of a TV transmission tower, its height should be multiplied by :

- (1) 2 (2) $\frac{1}{\sqrt{2}}$ (3) $\sqrt{2}$ (4*) 4

Sol. Covering range of transmission power = $\sqrt{2hR}$

To double the range make height 4 times.

66. Let ℓ , r , c and v represent inductance, resistance, capacitance and voltage, respectively. The dimension of $\frac{\ell}{rcv}$ in SI units will be:

- (1) [LTA] (2) [LA⁻²] (3) [LT²] (4*) [A⁻¹]

Sol. $\frac{L}{RCV} = [A^{-1}]$

67. In the circuit shown, find C if the effective capacitance of the whole circuit is to be 0.5 μF. All values in the circuit are in μF.

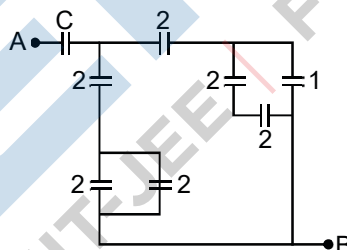

- (1) $\frac{6}{5} \mu F$ (2*) $\frac{7}{11} \mu F$ (3) 4 μF (4) $\frac{7}{10} \mu F$

Sol. $C_{eq} = 0.5 \mu F = \frac{\left(1 + \frac{4}{3}\right)C}{\frac{7}{3} + C} = \frac{7C}{\frac{7}{3} + C} = \frac{1}{2}$

$$\Rightarrow \frac{14C}{3} = C + \frac{7}{3}$$

$$C = \frac{7}{11}$$

68. A long cylindrical vessel is half filled with a liquid. When the vessel is rotated about its own vertical axis, the liquid rises up near the wall. If the radius of vessel is 5 cm and its rotational speed is 2 rotations per second, then the difference in the heights between the centre and the sides, in cm, will be :
- (1) 1.2 (2) 0.4 (3) 0.1 (4*) 2.0

Sol.
$$y = \frac{w^2 x^2}{2g} = \frac{(2 \times 2\pi)^2 \times (0.05)^2}{2g}$$

$$= 125 \times 8 \times 10^{-4}$$

$$= 2 \text{ cm}$$

69. A load of mass M kg is suspended from a steel wire of length 2m and radius 1.0 mm in Searle's apparatus experiment. The increase in length produced in the wire is 4.0 mm. Now the load is fully immersed in a liquid of relative density 2. The relative density of the material of load is 8. The new value of increase in length of the steel wire is:
- (1) 5.0 mm (2) 4.0 mm (3) zero (4*) 3.0 mm

Sol. in first case:

$$\frac{\frac{mg}{A}}{\left(\frac{\Delta l_1}{l}\right)} = Y \Rightarrow \Delta l_1 = \left(\frac{YA}{l}\right)$$

In second case:

$$\frac{\frac{mg - B}{A}}{\left(\frac{\Delta l_2}{l}\right)} = Y \Rightarrow \Delta l_2 = \frac{mg - B}{\left(\frac{YA}{l}\right)} = \frac{\left(\frac{3mg}{4}\right)}{\left(\frac{YA}{l}\right)}$$

$$\Rightarrow \Delta l_2 = \frac{3}{4} \Delta l_1 = 3 \text{ mm}$$

70. The charge on a capacitor plate in a circuit, as a function of time, is shown in the figure: What is the value of current at t = 4s?

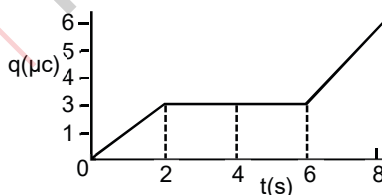

- (1*) zero (2) 1.5 μA (3) 2 μA (4) 3 μA

Sol. Current = slope of q – t graph = 0. [at t = 4 sec]

71. A particle of mass 20 g is released with an initial velocity 5 m/s along the curve from the point A, as shown in the figure. The point A is at height h from point B. The particle slides along the frictionless surface. When the particle reaches point B, its angular momentum about O will be: (Take g = 10 m/s²)

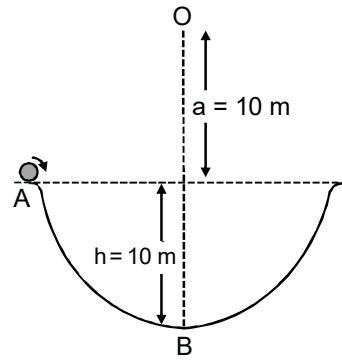

- (1) $3 \text{ kg-m}^2/\text{s}$ (2) $2 \text{ kg-m}^2/\text{s}$ (3) $8 \text{ kg-m}^2/\text{s}$ (4*) $6 \text{ kg-m}^2/\text{s}$

Sol. $v = \sqrt{5^2 + 2gh} = \sqrt{5^2 + 2 \times 10 \times 10} = \sqrt{225} = 15 \text{ m/s}$

$h = rmv \times 20 \times (20 \times 10^{-3} \text{ kg}) \times (15)$
 $= 6 \text{ kg m}^2/\text{sec}$

72. A 10 m long horizontal wire extends from North East to South West. It is falling with a speed of 5.0 ms^{-1} , at right angles to the horizontal component of the earth's magnetic field, of $0.3 \times 10^{-4} \text{ Wb/m}^2$. The value of the induced emf in wire is:

- (1) $2.5 \times 10^{-3} \text{ V}$ (2) $1.1 \times 10^{-3} \text{ V}$ (3*) $1.5 \times 10^{-3} \text{ V}$ (4) $0.3 \times 10^{-3} \text{ V}$

Sol. $\therefore \text{Emf} = Blv \sin 45^\circ$

$= (0.3 \times 10^{-4}) (10) \times 5 \times \frac{1}{2}$
 $= 1.1 \times 10^{-3} \text{ V}$

73. In the above circuit, $C = \frac{\sqrt{3}}{2} \mu\text{F}$, $R_2 = 20 \Omega$, $L = \frac{\sqrt{3}}{10} \text{ H}$ and $R_1 = 10 \Omega$. Current in L- R_1 path is I_1 and in C- R_2 path it is I_2 . The voltage of A.C source is given by, $V = 200\sqrt{2} \sin (100t)$ volts. The phase difference between I_1 and I_2 is

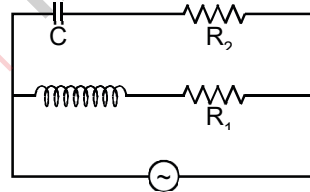

- (1*) 90° (2) 0° (3) 30° (4) 60°

Sol. For the first branch:

$\tan \phi_1 = \frac{-X_C}{R_2} = \frac{1}{20} \times \left(\frac{100 \times \frac{\sqrt{3}}{2} \times 10^{-6}}{1} \right) \approx -10^{-3}$
 $\Rightarrow \phi_1 \approx -90^\circ$

For the second branch:

$$\tan \phi_2 = \frac{X_L}{R} = \sqrt{3}$$

$$\Rightarrow \phi_2 \approx -90^\circ.$$

Phase difference between current in branch 1 and 2 = 150° .

No option is correct.

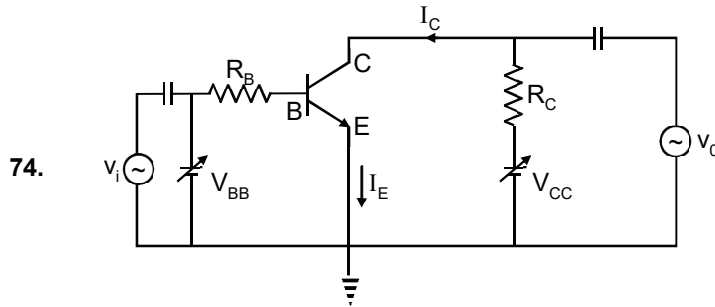

In the figure, given that V_{BB} supply can vary from 0 to 5.0 V, $V_{CC} = 5$ V, $\beta_{dc} = 200$, $R_B = 100$ k Ω , $R_C = 1$ k Ω and $V_{BE} = 1.0$ V. The minimum base current and the input voltage at which the transistor will go to saturation, will be, respectively:

- (1) 20 μ A and 3.5 V (2*) 25 μ A and 3.5 V (3) 20 μ A and 2.8 V (4) 25 μ A and 2.8 V

Sol. When switched on:

$$V_{CE} = 0$$

$$V_{CC} - R_C I_C = 0$$

$$i_c = \frac{V_{CC}}{R_C} = 5 \times 10^{-3} \text{ A}$$

$$I_C = \beta i_B$$

$$\Rightarrow i_B = 25 \mu\text{A}$$

$$\Rightarrow V_{BB} = i_B R_B - V_{BE} = 0$$

$$\Rightarrow V_{BB} = V_{BE} + i_B R_B = 3.5 \text{ V}$$

75. A paramagnetic material has 10^{28} atoms/m³. Its magnetic susceptibility at temperature 350 K is 2.8×10^{-4} . Its susceptibility at 300 K is:

- (1) 3.672×10^{-4} (2) 3.726×10^{-4} (3) 2.672×10^{-4} (4*) 3.267×10^{-4}

Sol. For paramagnetic materials $\chi \propto \frac{1}{R}$

$$\frac{\chi_1}{\chi_2} = \frac{T_2}{T_1}$$

$$\Rightarrow \chi_2 = \frac{T_1}{T_2} \times \chi_1 = \frac{350}{300} \times 2.8 \times 10^{-4}$$

$$= 3.267 \times 10^{-4}$$

76. A plano-convex lens (focal length f_2 , refractive index μ_2 , radius of curvature R) fits exactly into a plano-concave lens (focal length f_1 , refractive index μ_1 , radius of curvature R). Their plane surfaces are parallel to each other. Then, the focal length of the combination will be:

(1) $\frac{2f_1f_2}{f_1+f_2}$ (2) $f_1 - f_2$ (3*) $\frac{R}{\mu_2 - \mu_1}$ (4) $f_1 + f_2$

Sol. $\frac{1}{f} = \frac{(\mu_1 - 1)}{R} + \frac{(1 - \mu_2)}{R}$
 $\frac{1}{f} = \frac{(\mu_1 - \mu_2)}{R}$
 $\Rightarrow f = \frac{R}{\mu_1 - \mu_2}$

77. A vertical closed cylinder is separated into two parts by a frictionless piston of mass m and of negligible thickness. The piston is free to move along the length of the cylinder. The length of the cylinder above the piston is l_1 , and that below the piston is l_2 , such that $l_1 > l_2$. Each part of the cylinder contains n moles of an ideal gas at equal temperature T . If the piston is stationary, its mass, m , will be given by :
 (R is universal gas constant and g is the acceleration due to gravity)

(1) $\frac{nRT}{g} \left[\frac{1}{l_2} + \frac{1}{l_1} \right]$ (2*) $\frac{nRT}{g} \left[\frac{l_1 - l_2}{l_1 l_2} \right]$ (3) $\frac{RT}{ng} \left[\frac{l_1 - 3l_2}{l_1 l_2} \right]$ (4) $\frac{RT}{g} \left[\frac{2l_1 + l_2}{l_1 l_2} \right]$

Sol. $P_2A - P_1A = mg$

$$m = \frac{1}{g} \left(\frac{P_1 A l_1}{l_1} - \frac{P_2 A l_2}{l_2} \right)$$

$$m = \frac{1}{g} \left(\frac{nRT}{l_1} - \frac{nRT}{l_2} \right)$$

$$m = \frac{nRT}{g} \left(\frac{1}{l_1} - \frac{1}{l_2} \right)$$

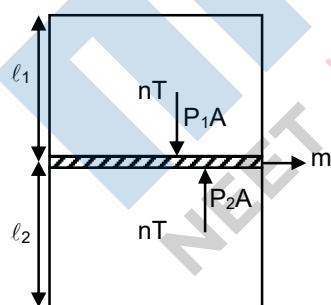

78. A soap bubble, blown by a mechanical pump at the mouth of a tube, increases in volume, with time, at a constant rate. The graph that correctly depicts the time dependence of pressure inside the bubble is given by:

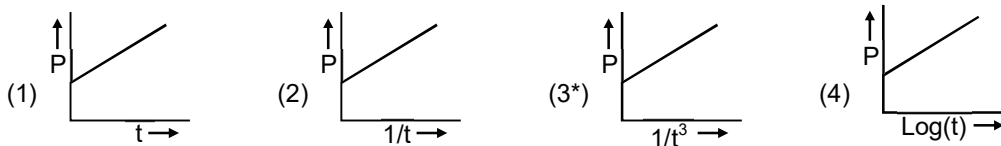

Sol. $V = kt = \frac{4}{3}\pi R^3$

$$R = \left(\frac{3k}{4\pi}t\right)^{1/3}$$

$$P_{in} = P_{atm} + \frac{4T}{R}$$

⇒ Bonus

79. Two particles A, B are moving on two concentric circles of radii R_1 and R_2 with equal angular speed ω . At $t = 0$, their positions and direction of motion are shown in the figure.

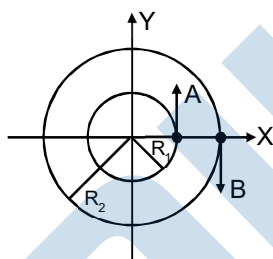

The relative velocity $\vec{v}_A - \vec{v}_B$ at $t = \frac{\pi}{2\omega}$ is given by :

- (1*) $\omega(R_2 - R_1)\hat{i}$ (2) $-\omega(R_1 + R_2)\hat{i}$ (3) $\omega(R_1 + R_2)\hat{i}$ (4) $\omega(R_1 - R_2)\hat{i}$

Sol. $\vec{V}_A - \vec{V}_B = -\omega R_1\hat{i} + \omega R_2\hat{i}$
 $= \omega(R_2 - R_1)\hat{i}$

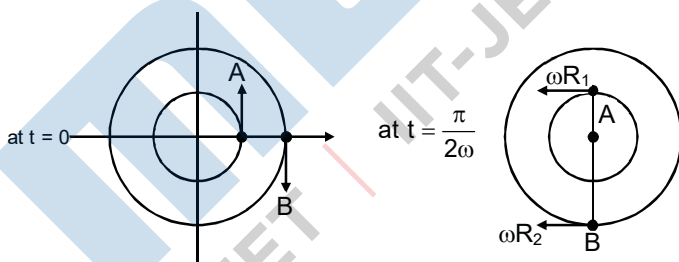

80. Two satellites, A and B, have masses m and $2m$ respectively. A is in a circular orbit of radius R , and B is in a circular orbit of radius $2R$ around the earth. The ratio of their kinetic energies, T_A/T_B , is :

- (1) 2 (2*) 1 (3) (4)

Sol. $KE_A = \frac{1}{2}m\left(\frac{GM}{R}\right)$

$$KE_B = \frac{1}{2}(2m)\left(\frac{GM}{2R}\right)$$

$$\Rightarrow \frac{KE_A}{KE_B} = 1$$

81. In the given circuit diagram, the currents, $I_1 = -0.3$ A, $I_4 = 0.8$ A and $I_5 = 0.4$ A, are flowing as shown. The currents I_2 , I_3 and I_6 , respectively, are :

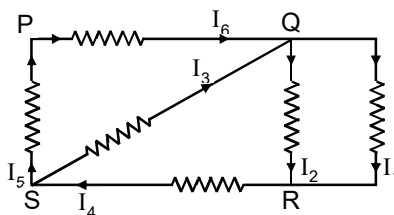

- (1) 0.4 A, 1.1 A, 0.4 A
 (2*) 1.1 A, 0.4 A, 0.4 A
 (3) -0.4 A, 0.4 A, 1.1 A
 (4) 1.1 A, -0.4 A, 0.4 A

Sol. $I_3 + I_5 = I_4 \Rightarrow I_3 = I_4 - I_5 = 0.4$ A
 $I_1 + I_2 = I_4 \Rightarrow I_2 = I_4 - I_1 = 1.1$ A
 $I_3 + I_6 = I_2 + I_1 \Rightarrow I_6 = I_2 + I_1 - I_3 = 0.4$ A

82. In a radioactive decay chain, the initial nucleus is ${}_{90}^{232}\text{Th}$. At the end there are 6 α -particles and 4 β -particles which are emitted. If the end nucleus is X, A and Z are given by :

- (1*) A = 208 ; Z = 82
 (2) A = 200 ; Z = 81
 (3) A = 202 ; Z = 80
 (4) A = 208 , Z = 80

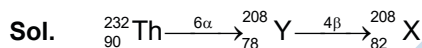

83. A galvanometer, whose resistance is 50 ohm, has 25 divisions in it. When a current of 4×10^{-4} A passes through it, its needle (pointer) deflects by one division. To use this galvanometer as a voltmeter of range 2.5 V, it should be connected to a resistance of :

- (1*) 200 ohm (2) 6250 ohm (3) 6200 ohm (4) 250 ohm

Sol. $V_o = i_{go}(R_G + R)$
 $i_{go} = 4 \times 10^{-4} \times 25 = 10^{-2}$ A
 $V_o = 2.5$ V
 $R_g + R = \frac{V_o}{i_{go}} = \frac{2.5}{10^{-2}} = 250$
 $\Rightarrow R = 200 \Omega$.

84. An alpha-particle of mass m suffers 1-dimensional elastic collision with a nucleus at rest of unknown mass. It is scattered directly backwards losing, 64% of its initial kinetic energy. The mass of the nucleus is :

- (1*) 4m (2) 2m (3) 1.5 m (4) 3.5 m

Sol. (I) $mv_o = -mv_1 + mv_2$
 (II) $v_o = v_1 + v_2$

$$\frac{2mv_0}{m+M} = V_2$$

$$KE_f = \frac{1}{2}mv_1^2 = \frac{1}{2}m\left(\frac{M-m}{M+m}\right)^2 v_0^2 = \frac{36}{100} \times \frac{1}{2}mv_0^2$$

$$\Rightarrow M = 4 m.$$

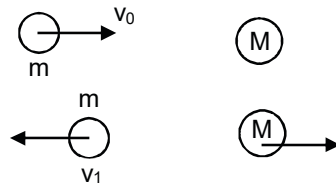

85. A resonance tube is old and has jagged end. It is still used in the laboratory to determine velocity of sound in air. A tuning fork of frequency 512 Hz product first resonance when the tube is filled with water to a mark 11 cm below a reference mark, near the open end of the tube. The experiment is repeated with another fork of frequency 256 Hz which produces first resonance when water reaches a mark 27 cm below the reference mark. The velocity of sound in air, obtained in the experiment, is close to :

- (1*) 328 ms⁻¹ (2) 322 ms⁻¹ (3) 341 ms⁻¹ (4) 335 ms⁻¹

Sol. $\lambda_1 = 4(11+e) \frac{v}{512}$

$$\lambda_2 = 4(27+e) \frac{v}{256}$$

$$\frac{11+e}{27+e} = \frac{1}{2}$$

$$\Rightarrow 22 + 2e = 27 + e$$

$$\Rightarrow e = 5$$

86. A block kept on a rough inclined plane, as shown in the figure, remains at rest upto a maximum force 2N down the inclined plane. The maximum external force up the inclined plane that does not move the block is 10 N. The coefficient of static friction between the block and the plane is :

[Take g = 10 m/s²]

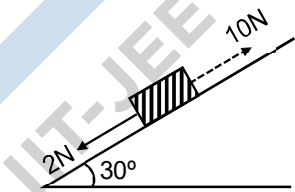

- (1) $\frac{\sqrt{3}}{4}$ (2) $\frac{2}{3}$ (3*) $\frac{\sqrt{3}}{2}$ (4) $\frac{1}{2}$

Sol. $mg \sin \theta + 2 = \mu mg \cos \theta \dots(1)$

$$10 - mg \sin \theta = \mu mg \cos \theta \dots(2)$$

On adding: (1) + (2)

$$12 = 2\mu mg \frac{\sqrt{3}}{2} \quad ; \quad \mu mg = \frac{12}{\sqrt{3}}$$

On (1) - (2):

$$8 = 2 mg \times \frac{1}{2} \quad ; \quad mg = 8 \quad ; \quad \mu = \frac{\sqrt{3}}{2}$$

87. Formation of real image using a biconvex lens is shown below :

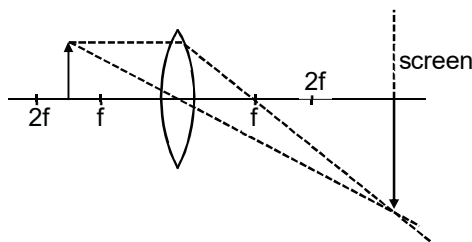

If the whole set up is immersed in water without disturbing the object and the screen positions, what will one observe on the screen?

- (1) No change (2*) Image disappears (3) Magnified image (4) Erect real image

Sol. If the water is filled focal length will decrease and image will disappear.

88. The mean intensity of radiation on the surface of the Sun is about 10^8 W/m^2 . The rms value of the corresponding magnetic field is closest to :

- (1) 10^{-2} T (2*) 10^{-4} T (3) 1 T (4) 10^2 T

Sol. $I = \frac{B_0^2}{2\mu_0} \times C$

$B_0^2 = I \times 2\mu_0 \times C$

$B_0^2 = \frac{10^8 \times 2 \times 4\pi \times 10^{-7}}{3 \times 10^8}$

$B_0 \approx 10^{-4} \text{ T}$

89. A simple harmonic motion is represented by :

$y = 5(\sin 3\pi t + \sqrt{3} \cos 3\pi t) \text{ cm}$

The amplitude and time period of the motion are :

- (1) $5 \text{ cm}, \frac{3}{2} \text{ s}$ (2) $5 \text{ cm}, \frac{2}{3} \text{ s}$ (3*) $10 \text{ cm}, \frac{2}{3} \text{ s}$ (4) $10 \text{ cm}, \frac{3}{2} \text{ s}$

Sol. $y = 5(\sin 3\pi t + \sqrt{3} \cos 3\pi t) \text{ cm}$

$\Rightarrow y = 10 \sin(3\pi t + \phi)$

$\Rightarrow A = 10 \text{ cm}$

$\Rightarrow T = \frac{2}{3} \text{ sec}$

90. When a certain photosensitive surface is illuminated with monochromatic light of frequency ν , the stopping potential for the photo current is $-V_0/2$. When the surface is illuminated by monochromatic light of frequency $\nu/2$, the stopping potential is $-V_0$. The threshold frequency for photoelectric emission is :

- (1) $\frac{4}{3}\nu$ (2) 2ν (3) $\frac{3}{2}\nu$ (4) $\frac{5\nu}{3}$

Ans. Bonus

Sol. $eV_s = h\nu - \phi$

$$\left\{ \frac{-eV_0}{2} = hv - \phi \right\} \times 2 \quad \dots\dots(1)$$

$$-eV = \frac{hv}{2} - \phi \quad \dots\dots(2)$$

$$0 = 2hv - 2\phi - \frac{hv}{2} + \phi$$

$$\phi = \frac{3hv}{2} \Rightarrow \quad v_{th} = \frac{3v}{2}$$

MENIIT
NEET | IIT-JEE | FOUNDATION